

BetaGuard® with Beta Tower®

1450/ 850 MOBILE ALUMINIUM TOWER

Assembly Guide

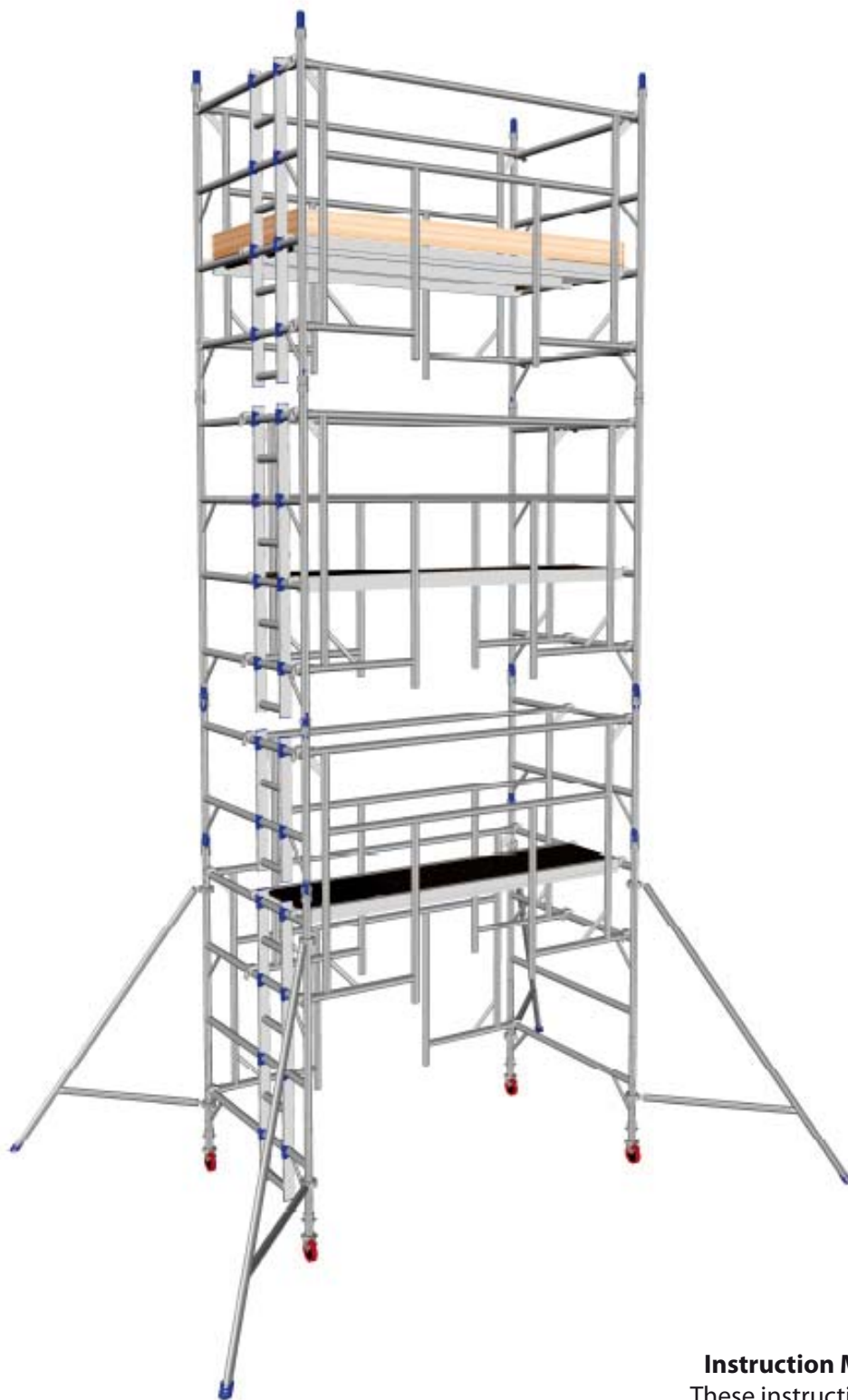

www.turner-access.co.uk

Instruction Manual EN 1298-IM-EN
These instructions and the equipment
described are in accordance with
BS EN 1298 and in compliance with **BS**
EN 1004:2004

Issued August 2010

INTRODUCTION

Please read this guide carefully.

The Beta Tower® is a Load Class 3 tower as specified in **BS EN 1004:2004**.

This instruction manual contains all the information required to correctly assemble the Beta Tower® incorporating the primary method of safe assembly of using Advanced Guardrail protection (BetaGuard®) to provide collective measures enabling full compliance with the Work at Height Regulations 2005.

The provision and utilisation of Advanced guardrail protection is recommended for all operatives erecting Beta Tower®.

This Manual should be used in conjunction with a suitable Risk Assessment and Method Statement (by user) relative to the project to be undertaken, Work at Height Regulations 2005, Regulation 6(1). It must be noted that all employers have a responsibility to ensure that work methods (practices) and adequate facilities/ resources (including work equipment) are provided to eliminate or minimise risks, Work at Height Regulations 2005, Regulations 6, 7, 8 and Schedule 3 Part 2.

Please ensure you read and fully understand the manual. Follow the content during assembly and ensure that the tower is correct and complete prior to use.

This manual must be made available to the user/ assembler at all times.

Sufficient training, combined with necessary experience, must also be considered and be appropriate to achieve competency to undertake basic mobile access tower assembly.

Only competent (and qualified) personnel should undertake erection, dismantling and alteration (and organisation, planning and supervision) of basic mobile access towers, Regulation 5, the Work at Height Regulations 2005 and consideration should be given to providing additional (minimum) training beforehand, if required (Regulation 6 (5)(b)).

For Technical advice (or further information) on TURNER Towers, please contact:

Turner Access Ltd, 65 Craigton Road, Glasgow, G51 3EQ

Tel: +44 (0) 141 309 5555 Fax: +44 (0) 141 309 5436

or e mail

enquiries@turner-access.co.uk

INSPECTION, CARE AND MAINTENANCE

Handle tower components with care to avoid damage to either the person handling the equipment or the equipment itself. Components need to be firmly secured and properly supported, when being transported, to prevent damage. In long term storage, towers should be protected from the weather. Prior to use, inspect all tower components for signs of damage or defects. Damaged, defective or incorrect components must be marked as unfit for use, withdrawn from use and either repaired or destroyed. Castors and adjustable legs should be periodically lubricated to keep them free running.

SAFETY

Refer to General Safety Notes and Advice for Users.

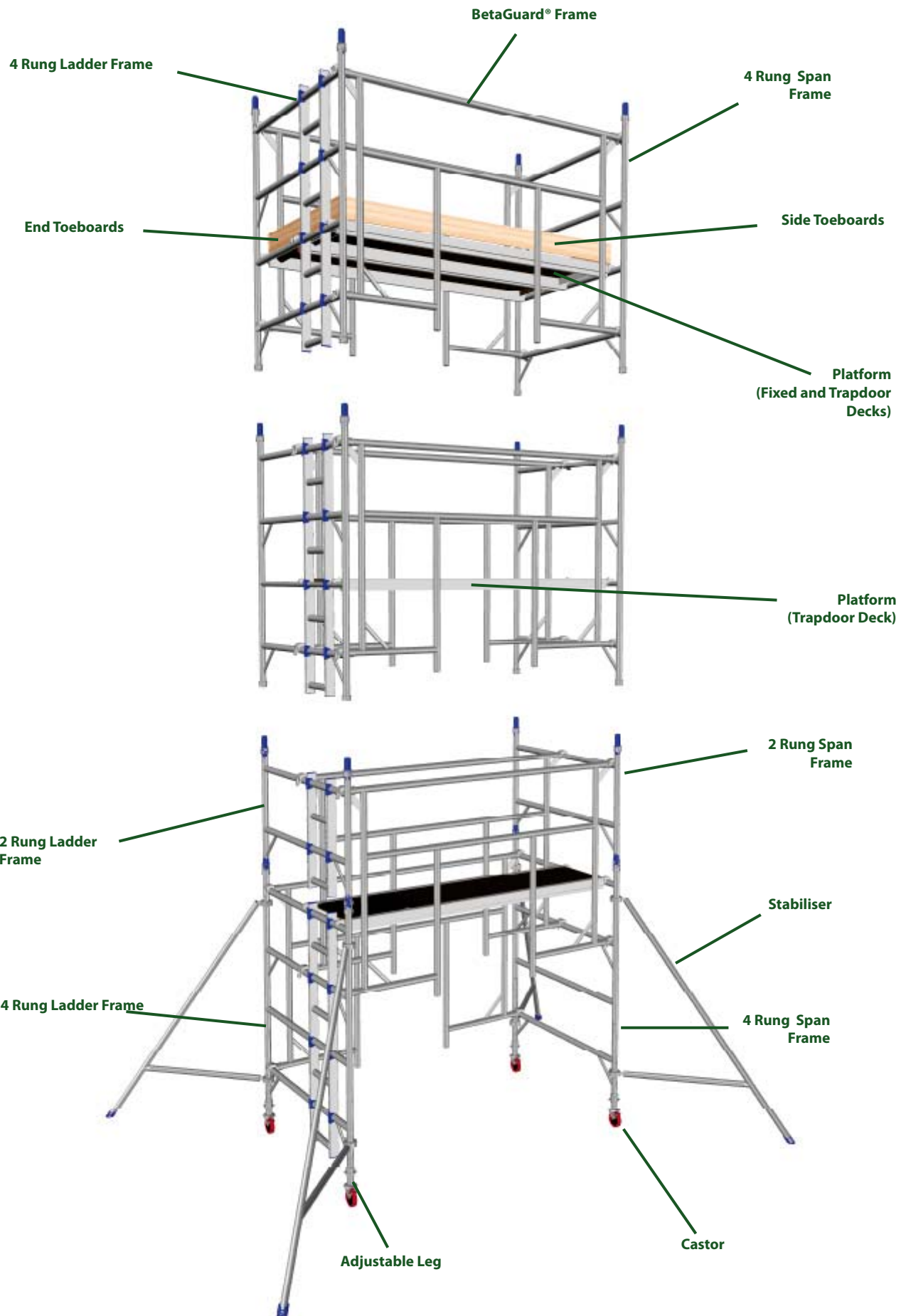

GENERAL SAFETY NOTES

1. Ensure that all necessary components and safety equipment (BetaGuard®) are available and operational.
2. Inspect the tower components for signs of damage or incorrect functioning prior to use. Damaged or incorrect components shall not be used. Castors and adjustable legs should be periodically lubricated to keep them free running.
3. Erect Exclusion zone and fit Warning Signs to comply with Schedule 3 Part 2 (11), Work at Height Regulations 2005.
4. Before erecting the tower, check that the location for the mobile access tower does not present any hazards during erection, dismantling, moving and safe working with respect to ground conditions, level and slope and obstructions.
5. Ensure the scaffolding is to be erected on suitable foundations capable of withstanding the loads imposed by the scaffolding (Schedule 3 Part 1(2) of Work at Height Regulations 2005) and, where appropriate, adequate sole boards to be provided.
6. It is recommended that at least two people erect and dismantle the tower.
7. Beta Tower® MUST ALWAYS be climbed from the inside, climbing the ladders only.
8. When lifting components or materials, always use reliable materials for lifting and tying methods to ensure there is no possibility of the tower overturning. Always lift from within the tower base. Ensure that the total weight of components or materials is within the maximum load per platform (300kg) and the maximum load for the overall tower (600kg).
9. Do not use hoisting arrangements on a mobile access tower.
10. The maximum wind condition for moving the mobile access tower are Beaufort Scale 0 - 4 as described in Table (Page 6). **Note** Cease working over 17 mph and do not attempt to move the tower.
11. Mobile access towers must only be moved manually, by pushing at the base.
Ensure that the platforms are free of persons and equipment and that brake locks are off prior to movement. Beware of soft or uneven ground and overhead obstructions.
The tower height must be reduced to 4m high and stabilisers raised approx 25mm clear of the ground. On completing the move apply all brakes and check adjustment and stability prior to completion of tower to full assembled height.
Note Tower height must be reduced to 2m high prior to any moves if less than 4 stabilisers are used in the position as indicated in Stabilisers section - pg.7)..
12. Always inspect the tower after moving and before use.
13. Always beware of live electrical apparatus, cables or moving parts of machinery.
14. Care should be taken when using power tools, wash jets or other tools that cause lateral force.
The maximum lateral force on a freestanding tower at platform level is 20kg.
15. DO NOT use boxes, ladders or other such means to gain additional height.
16. Never bridge between a tower and a building unless designed to a specification and approved.
17. Never jump onto platforms.
18. Fit guardrails at all platforms by following correct assembly procedures as described in this manual using BetaGuard®.
19. Fit toeboards on all working platforms.

20. Fit intermediate rest platforms at 4m intervals (maximum).
21. DO NOT affix sheeting of any type to the tower.
22. Mobile access towers are not designed to allow them to be lifted or suspended.
23. In accordance with regulations, any tower that has been erected must be inspected every 7 days (minimum) to ensure that the tower continues to comply with the regulations.

WIND SPEED SAFETY RULES

When locating the tower, check the wind conditions before erection, against the table, and beware of hazards during erection, dismantling and moving with respect to wind conditions and the funnelling effect of open ended, uncladded buildings and on building corners. Towers left unattended should be tied in to a rigid structure, especially when working outdoors or in exposed conditions. The maximum wind condition for moving the mobile access tower are Beaufort Scale 0 - 4 as described in table below.

Note Cease working over 17 mph and do not attempt to move the tower.

Beaufort Scale	Description	Air speed	Action
4	Moderate Breeze Small Branches move	13 - 17 mph	No action required
5 - 6	Strong Breeze Large branches bend	18 - 30 mph	Tie tower to a rigid structure
>6	Walking progress impeded	>31 mph	Dismantle tower if such conditions are expected

STABILISERS

Stabilisers should be attached so that the footprint of the tower, including stabilisers, is a square of the dimensions as shown.

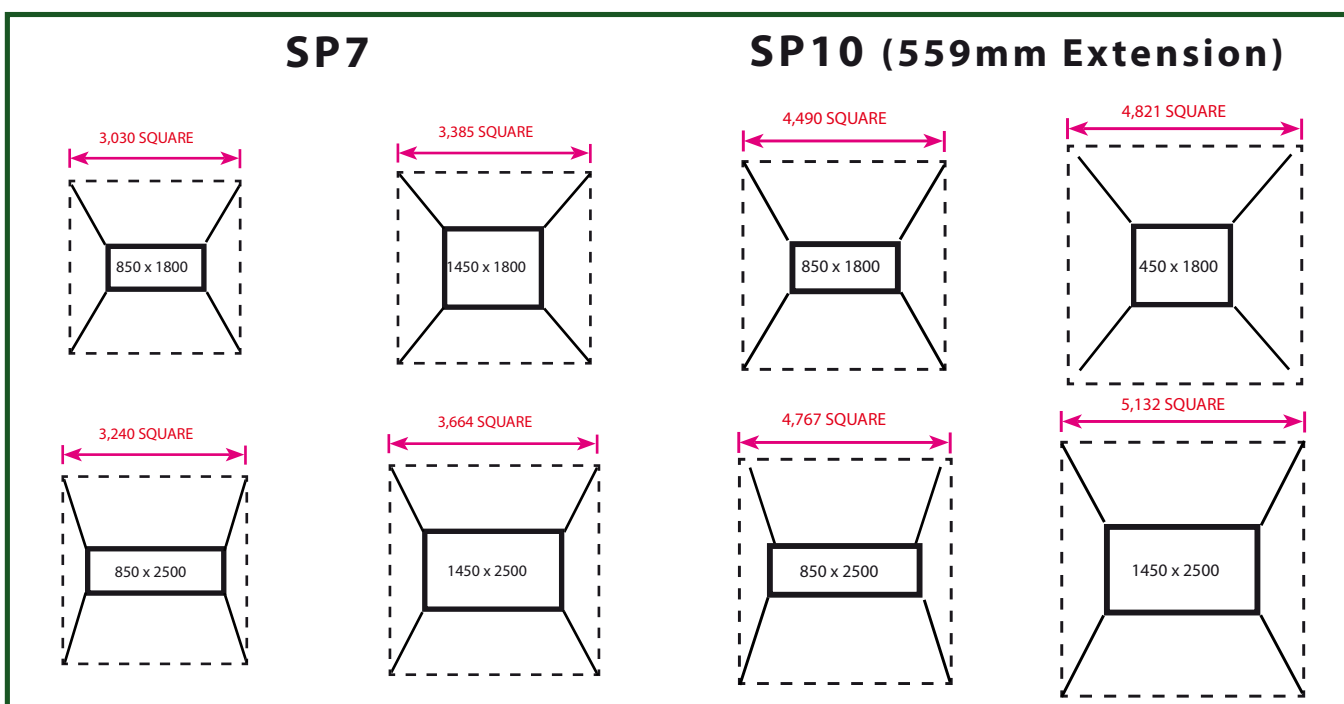

Larger stabilisers can be used at lower level to improve stability, if required.

TIES

If the safe tower height exceeds that as detailed in the Quantity schedule or the optimum base dimension cannot be constructed or other such factors that may affect the tower stability then, it will be necessary to rigidly tie the tower into an adjacent structure, using tubes and couplers suitable for coupling to the tower that has tube diameter of 50.8mm.

BetaGuard® FRAME

All BetaGuard® frames are fitted with self-priming triggers that automatically lock when attached to the tower.

Attach BetaGuard® frames square to the tower and remove by releasing the lower trigger.

When attaching BetaGuard® frames the claws always face down.

When dismantling the BetaGuard® frames, it is only necessary to release the lower triggers to remove the frame from the tower.

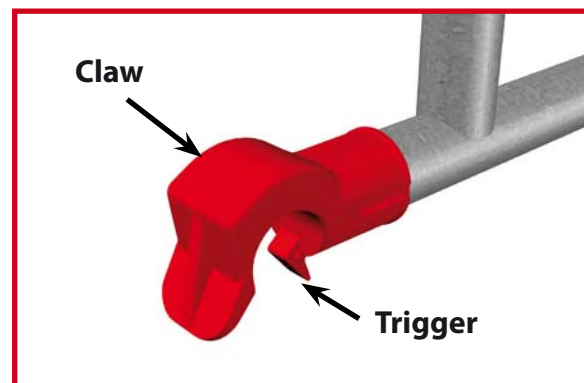
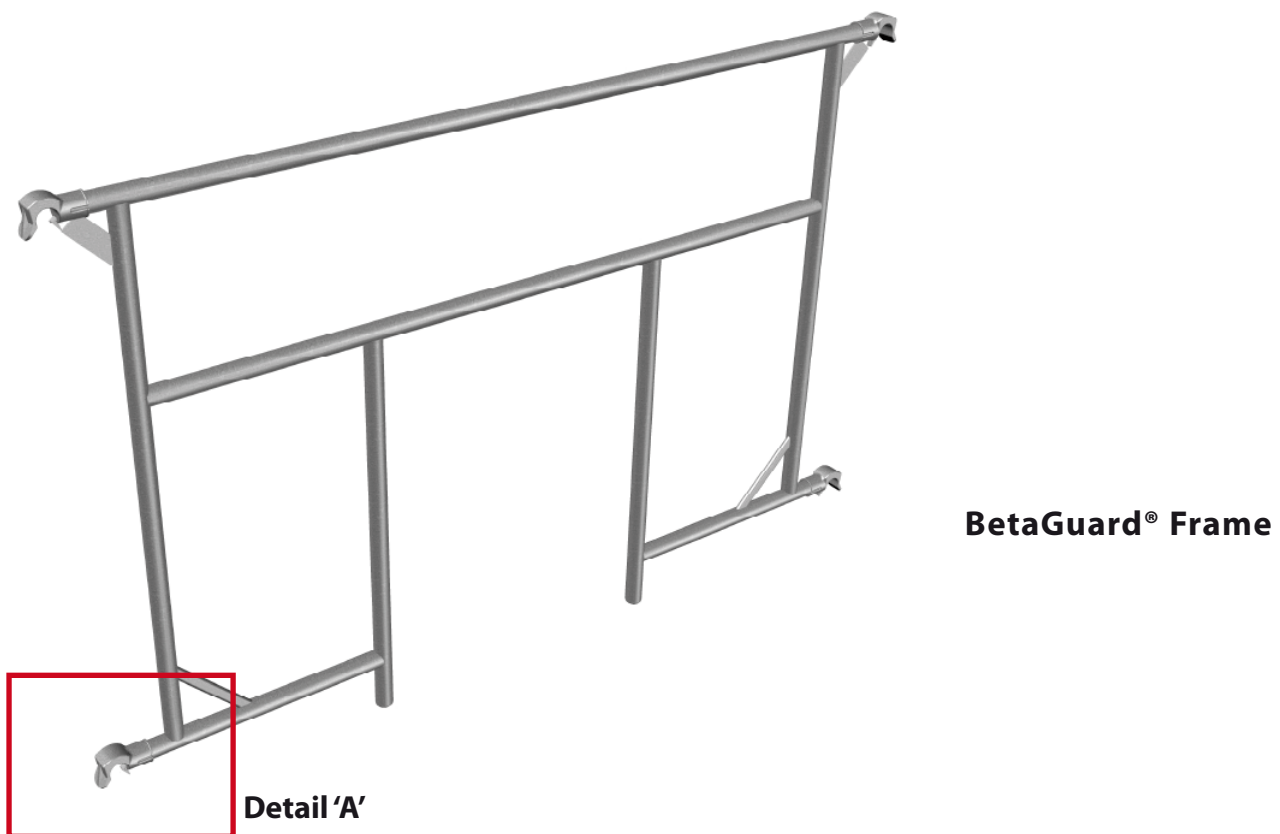

Detail 'A'

1450 Mobile Tower - 1.8m and 2.5m (complies with BS EN 1004:2004)

Internal/ External Use

Description	Working Height (m)	3.2	4.2	5.2	6.2	7.2	8.2	9.2	10.2	11.2	12.2	13.2	14.2
	Platform Height (m)	1.2	2.2	3.2	4.2	5.2	6.2	7.2	8.2	9.2	10.2	11.2	12.2
125/150mm Castor		4	4	4	4	4	4	4	4	4	4	4	4
250mm Adjustable Leg		4	4	4	4	4	4	4	4	4	4	4	4
1450 2 Rung Ladder Frame			1		1		1		1		1		1
1450 2 Rung Span Frame			1		1		1		1		1		1
1450 4 Rung Ladder Frame		1	1	2	2	3	3	4	4	5	5	6	6
1450 4 Rung Span Frame		1	1	2	2	3	3	4	4	5	5	6	6
1.8m and 2.5m Fixed Deck		1	1	1	1	1	1	1	1	1	1	1	1
1.8m and 2.5m Trap Door Deck		1	1	2	2	2	2	3	3	4	4	5	5
1.8m and 2.5m BetaGuard® Frame		2	3	4	5	6	7	8	9	10	11	12	13
1.8m and 2.5m Side Toeboard		2	2	2	2	2	2	2	2	2	2	2	2
1.2m End Toeboard		2	2	2	2	2	2	2	2	2	2	2	2

SP7 Fixed Stabiliser		4	4	4	4								
SP10 Telescopic Stabiliser (559mm Extension)							4	4	4	4	4	4	4

Total Tower self weight (kgs) 1.8m	91	127	159	179	196	224	256	276	308	328	360	380
Total Tower self weight (kgs) 2.5m	102	139	176	196	232	242	279	299	336	356	393	414

Note 200mm castors were used in the self weight calculations as detailed in the Quantity Schedule above.

Maximum Safe Working Loads (S.W.L.)

300kg per platform evenly distributed.

600kg per tower evenly distributed.

The platform can consist of either one deck or two decks (placed side by side).

The load **MUST** be evenly distributed over entire platform area (whether one deck or two decks).

A maximum of 2 platform levels may be loaded.

The self weight of the tower components is not part of the 600kg S.W.L. per tower and has already been taken into account.

Note You may increase the allowable Safe Working Load to 900kg by ensuring that all even height towers have two BetaGuard® frames in the base. Please contact your supplier if you require further information.

The Quantity Schedule provides for double handrails to all platforms. Toeboards have been included to one working platform only therefore additional toeboards will have to be added to any other levels that are used as working platforms and/ or for storage of materials.

Furthermore, product standards require that towers have platforms placed at least every 4m. The Schedule exceeds this requirement.

The Beta Tower® will be built safely and therefore compliance with the requirements of the Work at Height Regulations 2005 will also be met, if the schedule is followed.

Ballast: Internal/ External Use

Ballast is not required on Beta Tower® if using stabilisers as detailed on Quantity Schedule.

Note For towers with platform heights in additional 0.5m increments (eg 1.7m, 2.7m, etc.), please refer to Additional Quantity Schedules on pages 33 & 34 and assembly procedures for completing the base sections of these towers (pg 18 - Even Height towers & pg 28 - Odd Height towers).

850 Mobile Tower - 1.8m and 2.5m (complies with BS EN 1004:2004)

Internal/ External Use

Description	Working Height (m)	3.2	4.2	5.2	6.2	7.2	8.2	9.2	10.2	11.2	12.2	13.2	14.2
	Platform Height (m)	1.2	2.2	3.2	4.2	5.2	6.2	7.2	8.2	9.2	10.2	11.2	12.2
125/150mm Castor		4	4	4	4	4	4	4	4	4	4	4	4
250mm Adjustable Leg		4	4	4	4	4	4	4	4	4	4	4	4
850 2 Rung Ladder Frame			1		1		1		1		1		1
850 2 Rung Narrow Frame			1		1		1		1		1		1
850 4 Rung Ladder Frame		1	1	2	2	3	3	4	4	5	5	6	6
850 4 Rung Narrow Frame		1	1	2	2	3	3	4	4	5	5	6	6
1.8m and 2.5m Trap Door Deck		1	1	2	2	2	2	3	3	4	4	5	5
1.8m and 2.5m BetaGuard® Frame		2	3	4	5	6	7	8	9	10	11	12	13
1.8m and 2.5m Side Toeboard		2	2	2	2	2	2	2	2	2	2	2	2
0.6m End Toeboard		2	2	2	2	2	2	2	2	2	2	2	2
SP7 Fixed Stabiliser			4	4	4	4							
SP10 Telescopic Stabiliser (559mm Extension)							4	4	4	4	4	4	4
Total Tower self weight (kgs) 1.8m		73	107	138	156	172	198	229	247	278	296	327	345
Total Tower self weight (kgs) 2.5m		79	115	150	169	185	211	246	265	301	320	355	374

Note 200mm castors were used in the self weight calculations as detailed in the Quantity Schedule above.

Maximum Safe Working Loads (S.W.L.)

300kg per platform evenly distributed.

600kg per tower evenly distributed.

The load **MUST** be evenly distributed over entire platform area.

A maximum of 2 platform levels may be loaded.

The self weight of the tower components is not part of the 600kg S.W.L. per tower and has already been taken into account.

Note You may increase the allowable Safe Working Load to 900kg by ensuring that all even height towers have two BetaGuard® frames in the base. Please contact your supplier if you require further information.

The Quantity Schedule provides for double handrails to all platforms. Toeboards have been included to one working platform only therefore additional toeboards will have to be added to any other levels that are used as working platforms and/ or for storage of materials.

Furthermore, product standards require that towers have platforms placed at least every 4m. The Schedule exceeds this requirement.

The Beta Tower® will be built safely and therefore compliance with the requirements of the Work at Height Regulations 2005 will also be met, if the schedule is followed.

Ballast: Internal/ External Use

Ballast is not required on Beta Tower® if using stabilisers as detailed on Quantity Schedule.

Note For towers with platform heights in additional 0.5m increments (eg 1.7m, 2.7m, etc.), please refer to Additional Quantity Schedules on pages 33 & 34 and assembly procedures for completing the base sections of these towers (pg 18 - Even Height towers & pg 28 - Odd Height towers).

DAILY CHECKS

The tower must be checked on a daily basis and after any significant weather changes e.g. high winds, snow, frost.

Use the checklist below prior to use.

- Tower is vertical and square
- Tower structure is correct and complete
- Betaguard® correctly fitted and secure
- Castors locked/ legs correctly adjusted
- All castors, base plates and stabilisers are in contact with the ground
- Toeboards located and fixed correctly
- Correct stabilisers fitted, adjusted and secure
- Platforms locked and secure in position

If a box has not been ticked, do not use the tower until the fault is rectified.

Where a fault is found, access to the tower must be stopped.

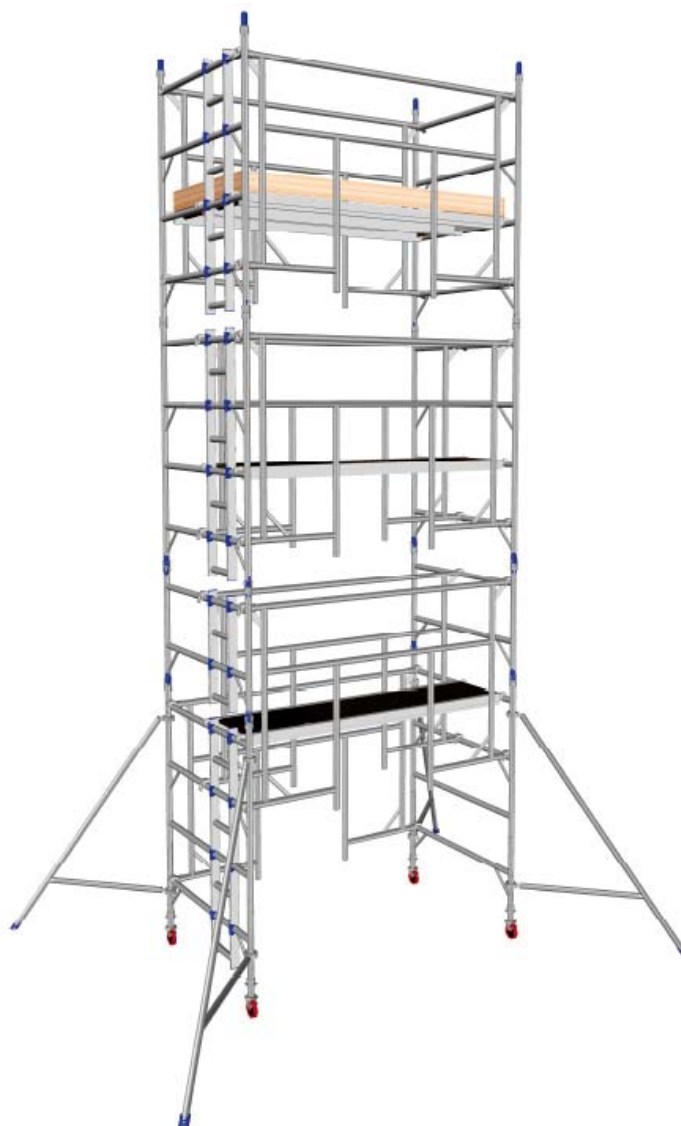

ASSEMBLY PROCEDURE 1450 TOWER

Our recommended method of assembly to fully comply with the Work at Height Regulations 2005, is by using Collective Protection which has been approved and endorsed by both PASMA and the HSE. The following assembly procedure uses BetaGuard® (Integral Advanced Guardrail).

If using the tower in a configuration beyond normal purpose the configuration can be supplemented with additional Turner Access approved compatible components to meet the performance levels required. Contact the supplier (or Turner Access Design Dept.) for further information.

NARROW WIDTH TOWERS

Narrow width towers are assembled following the same steps as explained for span towers, except that all platforms are trapdoor platforms.

EVEN HEIGHT TOWERS

THE BASE SECTION (2.2m; 4.2m; 6.2m; 8.2m; 10.2m; 12.2m)

1. Fit four legs to four castors (or base plates) and then turn the height adjustment collar on each leg until approximately 100mm from the lower end.
2. Set each castor brake on by moving the brake lever fully down.

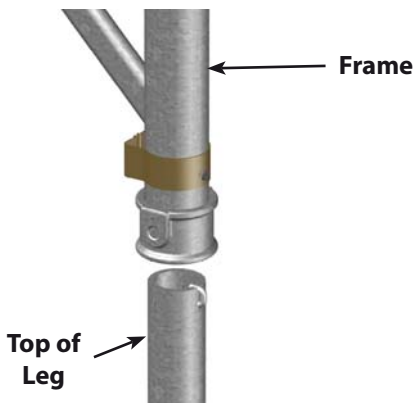
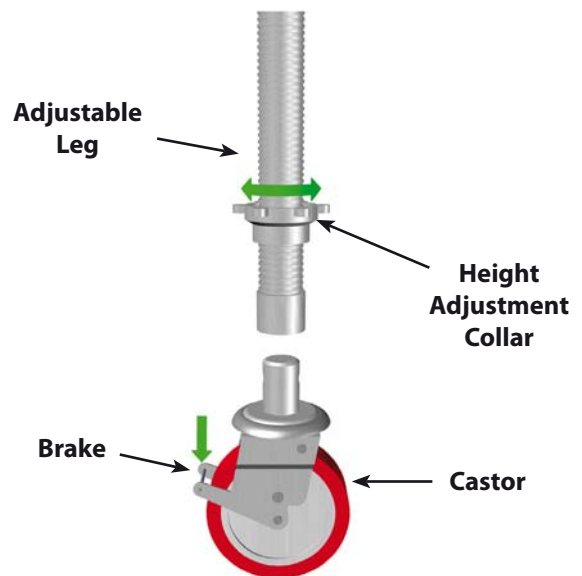

3. Fit leg assemblies to one 4 rung span frame and one 4 rung ladder frame. Insert each leg until the collar is in contact with the frame's tubing.

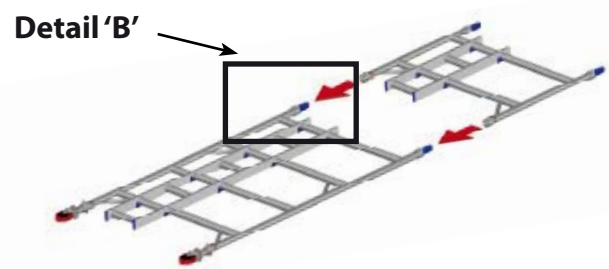
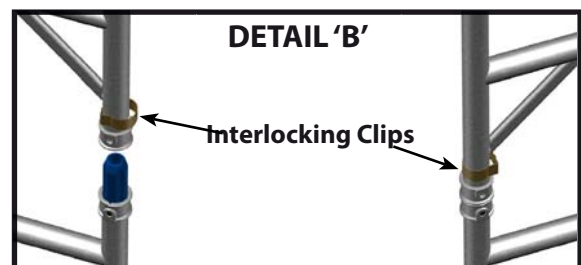

4. Add a 1m ladder frame to a 2m ladder frame (using 2 operatives) and lock frames together.
Note Ensure that the interlocking clips provided are correctly fitted and engaged (Detail 'B') when locking these and all subsequent frames.



5. Raise combined frames (ensuring that castors are locked) and attach the BetaGuard® frame at 1st and 4th rungs of tower frame.
Note It is strongly recommended that 2 operatives carry out this step

6. Attach the BetaGuard® frame to the opposing combined tower span frames and square the two frames to each other.
Note It may be advantageous to place a platform at low level to assist in "squaring" tower.

7. With the aid of a spirit level, you should now make any necessary adjustments to level the tower by turning the adjustment collars.
Note Remove platform when tower is "square". NEVER stand on an UNGUARDED platform.



8. Add a BetaGuard® frame to the centre of the tower (approx.) at 3rd rung of lower tower frame and top rung of upper tower frame, at a suitable distance apart to allow for the placing of a trapdoor platform.
9. Attach another BetaGuard® frame at the same level as previous BetaGuard® frame (opposite existing BetaGuard® frame) set as near as possible to frame vertical.



Stabilisers

Stabilisers or outriggers shall always be fitted when specified. See Quantity Schedule for the correct stabilisers or outriggers.

Note SP10 stabilisers are extended by 559mm (see below)

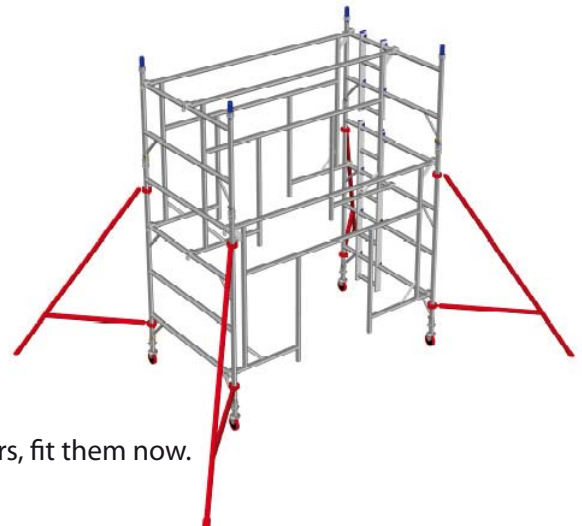
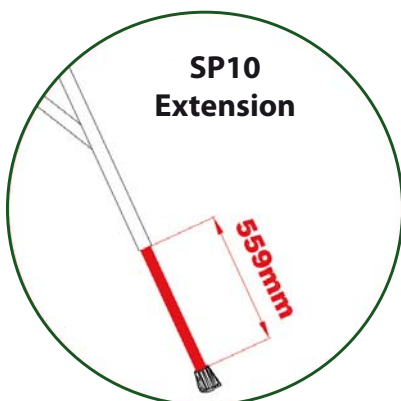

When using standard stabilisers, fit them now.

To attach the stabiliser, fit the upper screw clamp to the frame vertical at a position below the top rung of the lower 2m frame, then fit the lower screw clamp as low as possible to the frame upright.

Stabilisers should be attached so that the footprint of the tower, including stabilisers, is a square of the dimensions shown on page 6. Ensure that the stabilisers are in firm contact with the ground.

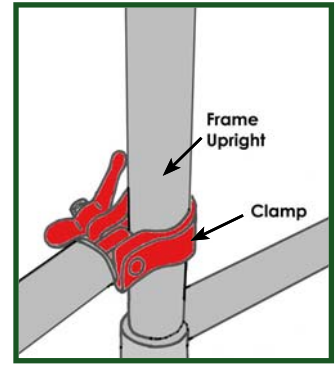

Notes

It may be advantageous to ensure that stabilisers are fitted from frame side as shown.

It may only be possible to fit extended stabilisers after upper frame has been placed.

If repositioning stabilisers when in position then screw clamps MUST be loosened prior to movement then re-fixed.

10. Place trapdoor platform at 2m level (4 rungs from ground) between BetaGuard® frames ensuring that platform trap is placed to the ladder side of the tower.



ASSEMBLING UPPER FRAMES

INTERMEDIATE SECTIONS

When the base section is complete then assembly of the upper frames can commence.

Every 2m section (intermediate section) between the base section and working platform (whether ODD or EVEN height tower) is assembled using the same components and steps that follow (steps 11 to 14).

11. Add one 4 rung ladder frame and one 4 rung span frame on top of existing ladder and span frames, respectively.



12. Attach one BetaGuard® frame to the centre of the tower to the ladder edge between tower frames at 1st and 4th rungs of upper frames at a suitable distance apart to allow for the placing of a trapdoor platform.

13. Attach another BetaGuard® frame on 1st and 4th rungs of upper frames set as near to frame vertical as possible (opposite existing BetaGuard® frame) to provide protection to ladder.





14. Place trapdoor platform at 4m platform height between BetaGuard® frames (above platform placed at lower level) ensuring that platform trap is placed to the ladder side of the tower.

Repeat steps 11 to 14 until desired height has been reached (max. height 8m outdoors and 12 m indoors) until top platform is to be installed.

ASSEMBLING UPPER FRAMES

TOP (WORKING) PLATFORM SECTIONS

Every Working platform, whether it is situated at the top or between intermediate sections (ODD or EVEN height tower) is assembled using the same components and steps that follow.



15. Add one ladder frame and one span frame on top of existing ladder and span frames, respectively.

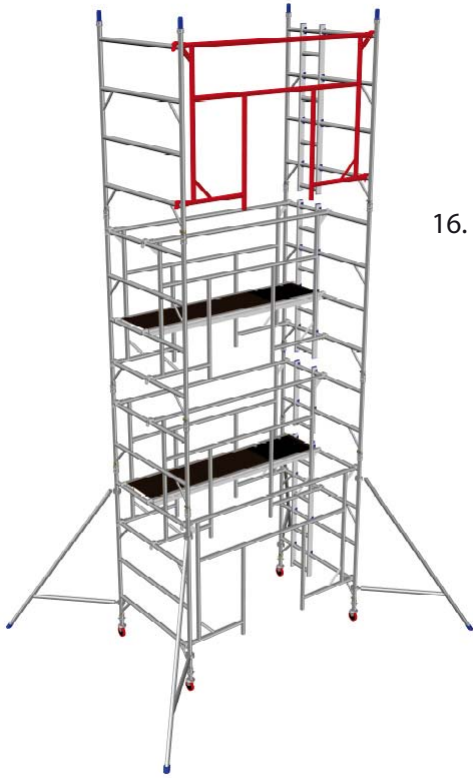

16. Attach two BetaGuard® frames between upper tower frames on 1st and 4th rungs set as near to frame verticals as possible on opposite sides of the tower.



17. Place fixed platform to opposite side of tower, from where operative is standing below,

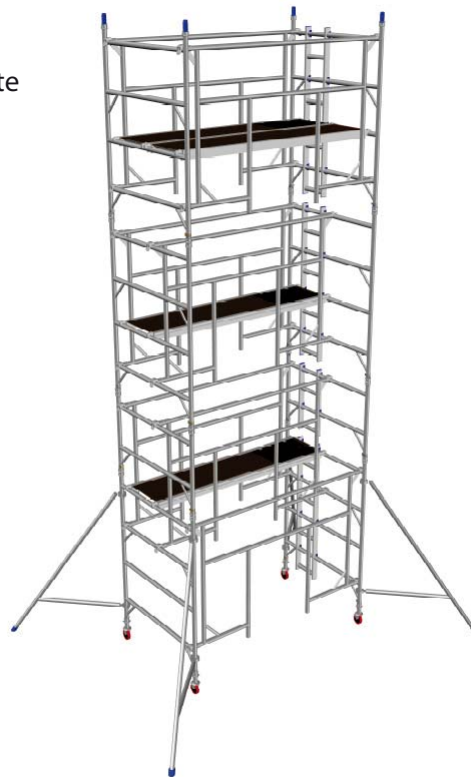

18. Place trapdoor platform ensuring that trap is placed at same side to trap on platform below.
Note Ensure that the trapdoor hinge is to the outside edge.

19. Fit toeboards to all working platforms.

Scaffold is complete.



DISMANTLING THE TOWER

The dismantling procedure is simply a reversal of the steps explained for the assembly.

For your safety and that of others, take particular care not to allow components to fall to the ground since this will not only result in damage but may cause serious injury.

EVEN HEIGHT TOWERS

THE BASE SECTION (2.7m; 4.7m; 6.7m; 8.7m; 10.7m; 12.7m)

The following instructions are for Even height towers with additional platform heights of 0.5m as detailed above (see Quantities Schedule - page 33 & 34 for equipment to suit).

1. Fit four legs to four castors (or base plates) and then turn the height adjustment collar on each leg until approximately 100mm from the lower end.
2. Set each castor brake on by moving the brake lever fully down.

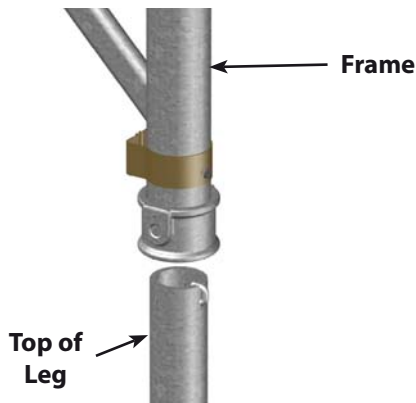
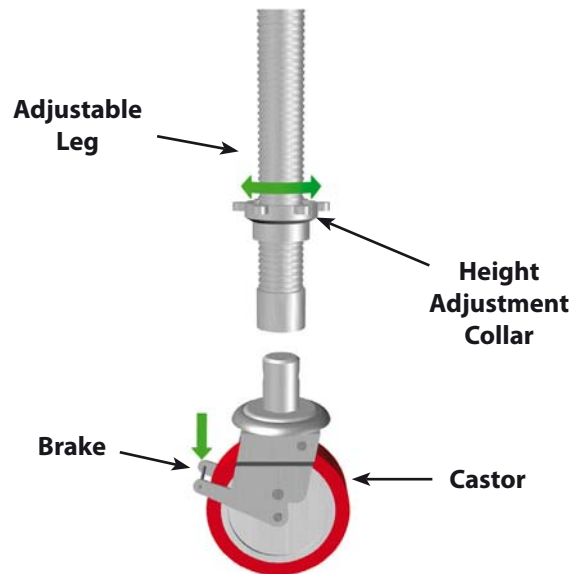

3. Fit leg assemblies to one 4 rung span frame and one 4 rung ladder frame. Insert each leg until the collar is in contact with the frame's tubing

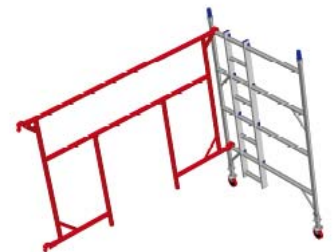

4. Attach the BetaGuard® frame at 1st and 4th rungs of tower frame set as near as possible to frame vertical.



5. Attach the BetaGuard® frame to the opposing tower span frame and square the two frames to each other.
Note It may be advantageous to place a platform at low level to assist in "squaring" tower.

6. With the aid of a spirit level, you should now make any necessary adjustments to level the tower by turning the adjustment collars.
Note Remove platform when tower is "square". NEVER stand on an UNGUARDED platform.

7. Add another BetaGuard® frame to the centre of the tower (approx.) at the same level as previous BetaGuard® frame, at a suitable distance apart to allow for the placing of a trapdoor platform.



Stabilisers

Stabilisers or outriggers shall always be fitted when specified. See Quantity Schedule for the correct stabilisers or outriggers.

Note SP10 stabilisers are extended by 559mm (see below)



When using standard stabilisers, fit them now.

To attach the stabiliser, fit the upper screw clamp to the frame vertical at a position below the top rung of the lower 2m frame, then fit the lower screw clamp as low as possible to the frame upright.

Stabilisers should be attached so that the footprint of the tower, including stabilisers, is a square of the dimensions shown on page 6. Ensure that the stabilisers are in firm contact with the ground.

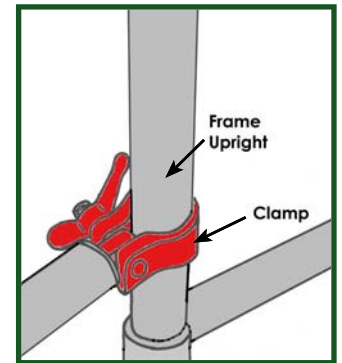

Notes

It may be advantageous to ensure that stabilisers are fitted from frame side as shown.

It may only be possible to fit extended stabilisers after upper frame has been placed.

If repositioning stabilisers when in position then screw clamps MUST be loosened prior to movement then re-fixed.



8. Place a trapdoor platform at 1m level (2 rungs from ground) between BetaGuard® frames ensuring that platform trap is placed to the ladder side of the tower.

9. Add one 3 rung ladder frame and one 3 rung span frame on top of existing ladder and span frames, respectively and lock frames together.

Note Ensure that the interlocking clips provided are correctly fitted and engaged (Detail 'C') when locking these and all subsequent frames.

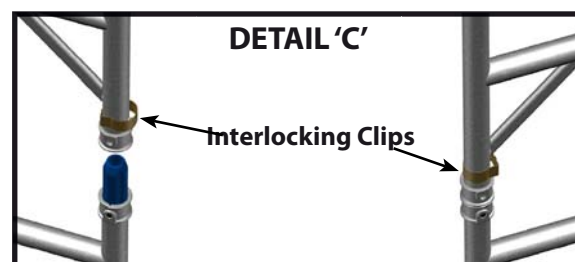



10. Attach two BetaGuard® frames between tower frames at top rungs of lower tower frames and top rungs of upper tower frames with one BetaGuard® frame set as near to frame vertical as possible and the other BetaGuard® frame to the centre of the tower (approx.) at a suitable distance apart to allow for the placing of a trapdoor platform.

11. Place trapdoor platform at 2.5m platform height (5 rungs from ground) between BetaGuard® frames ensuring that platform trap is placed to the ladder side of the tower.



ASSEMBLING UPPER FRAMES

INTERMEDIATE SECTIONS

When the base section is complete then assembly of the upper frames can commence.

Every 2m section (intermediate section) between the base section and working platform (whether ODD or EVEN height tower) is assembled using the same components and steps that follow (steps 12 to 15).

12. Add one 4 rung ladder frame and one 4 rung span frame on top of existing ladder and span frames, respectively.



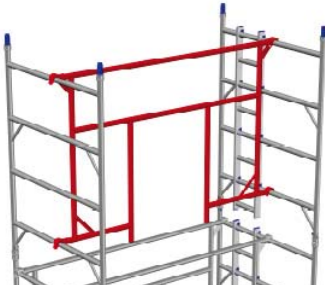

13. Attach one BetaGuard® frame to the centre of the tower to the ladder edge between tower frames at 1st and 4th rungs of upper frames at a suitable distance apart to allow for the placing of a trapdoor platform.

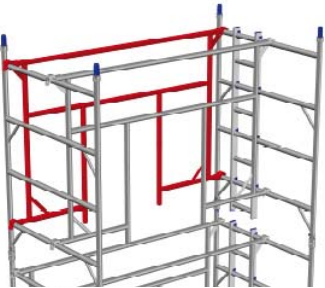

14. Attach another BetaGuard® frame set as near to frame vertical as possible (opposite existing BetaGuard® frame) to provide protection to ladder.



15. Place trapdoor platform at 4.5m platform height between BetaGuard® frames (above platform placed at lower level) ensuring that platform trap is placed to the ladder side of the tower.

Repeat steps 12 to 15 until desired height has been reached (max. height 8m outdoors and 12 m indoors) until top platform is to be installed.

ASSEMBLING UPPER FRAMES

TOP (WORKING) PLATFORM SECTIONS

Every Working platform, whether it is situated at the top or between intermediate sections (ODD or EVEN height tower) is assembled using the same components and steps that follow.



16. Add one ladder frame and one span frame on top of existing ladder and span frames, respectively.



17. Attach two BetaGuard® frames between upper tower frames on 1st and 4th rungs set as near to frame verticals as possible on opposite sides of the tower.

18. Place fixed platform to opposite side of tower, from where operative is standing below,

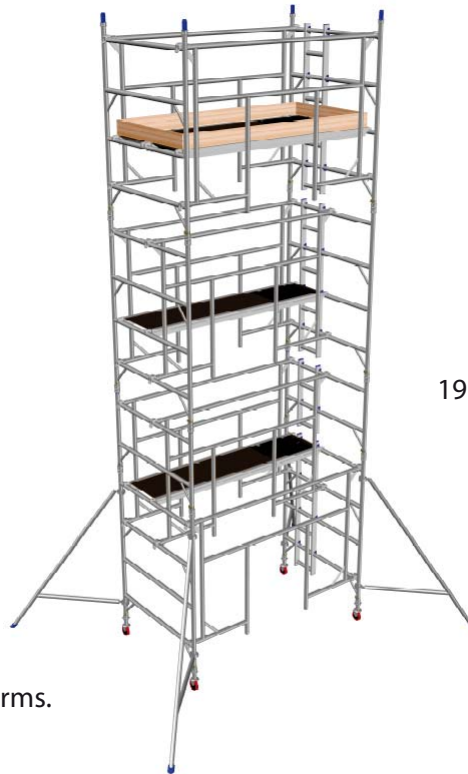

19. Place trapdoor platform ensuring that trap is placed at same side to trap on platform below.

Note Ensure that the trapdoor hinge is to the outside edge.

20. Fit toeboards to all working platforms.

Scaffold is complete.

DISMANTLING THE TOWER

The dismantling procedure is simply a reversal of the steps explained for the assembly.

For your safety and that of others, take particular care not to allow components to fall to the ground since this will not only result in damage but may cause serious injury.

ASSEMBLY PROCEDURE 1450 TOWER

ODD HEIGHT TOWERS

THE BASE SECTION (1.2m; 3.2m; 5.2m; 7.2m; 9.2m; 11.2m)

1. Fit four legs to four castors (or base plates) and then turn the height adjustment collar on each leg until approximately 100mm from the lower end.
2. Set each castor brake on by moving the brake lever fully down.

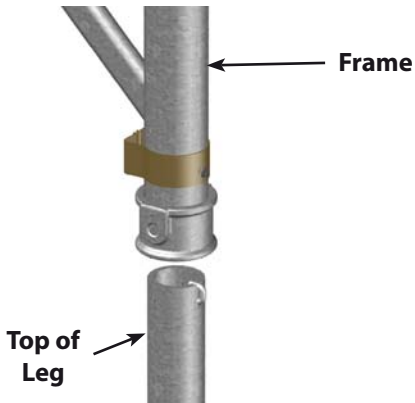
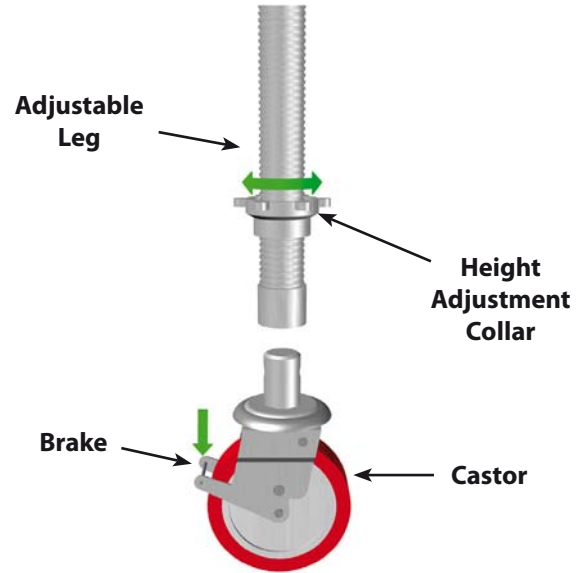

3. Fit leg assemblies to one 4 rung span frame and one 4 rung ladder frame. Insert each leg until the collar is in contact with the frame's tubing.

4. Attach the BetaGuard® frame at 1st and 4th rungs of tower frame set as near as possible to frame vertical.





- Attach BetaGuard® frame to the opposing tower span frame and square the two frames to each other.

Note It may be advantageous to place a platform at low level to assist in "squaring" tower.

- With the aid of a spirit level, you should now make any necessary adjustments to level the tower by turning the adjustment collars.

Note Remove platform when tower is "square". NEVER stand on an UNGUARDED platform.

- Add another BetaGuard® frame to the centre of the tower (approx.) at the same level as previous BetaGuard® frame, at a suitable distance apart to allow for the placing of a trapdoor platform.

- Place a trapdoor platform at 1m level (2 rungs from ground) between BetaGuard® frames ensuring that platform trap is placed to the ladder side of the tower.



Stabilisers

Stabilisers or outriggers shall always be fitted when specified. See Quantity Schedule for the correct stabilisers or outriggers.

Note SP10 stabilisers are extended by 559mm (see below)

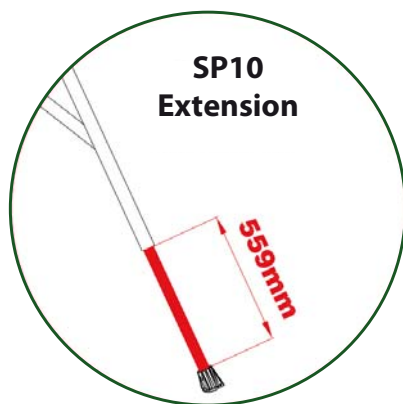

When using standard stabilisers, fit them now.

To attach the stabiliser, fit the upper screw clamp to the frame vertical at a position below the top rung of the lower 2m frame, then fit the lower screw clamp as low as possible to the frame upright.

Stabilisers should be attached so that the footprint of the tower, including stabilisers, is a square of the dimensions shown on page 6. Ensure that the stabilisers are in firm contact with the ground.

Notes

It may be advantageous to ensure that stabilisers are fitted from frame side as shown.

It may only be possible to fit extended stabilisers after upper frame has been placed.

If repositioning stabilisers when in position then screw clamps MUST be loosened prior to movement then re-fixed.

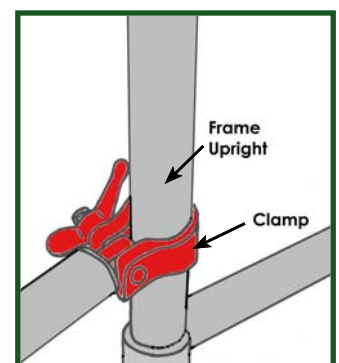

ASSEMBLING UPPER FRAMES

INTERMEDIATE SECTIONS

When the base section is complete then assembly of the upper frames can commence.

Every 2m section (intermediate section) between the base section and working platform (whether ODD or EVEN height tower) is assembled using the same components and steps that follow (steps 9 to 12).

9. Add one 4 rung ladder frame and one 4 rung span frame on top of existing ladder and span frames, respectively and lock frames together.

Note Ensure that the interlocking clips provided are correctly fitted and engaged (Detail 'D') when locking these and all subsequent frames.

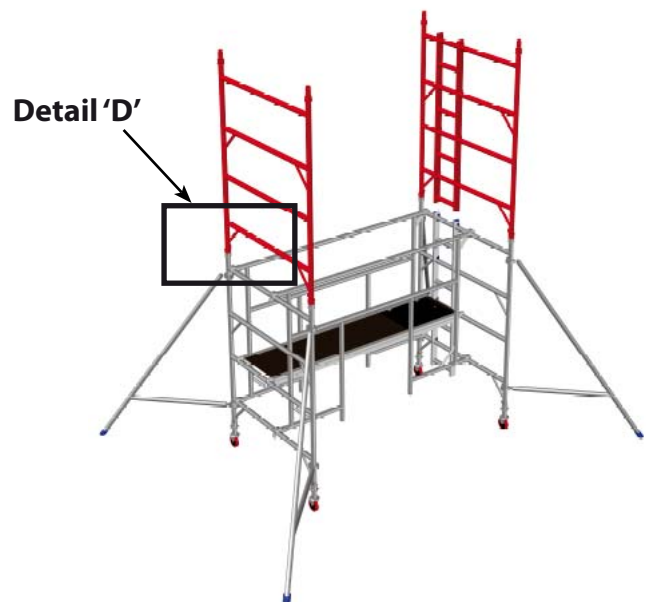
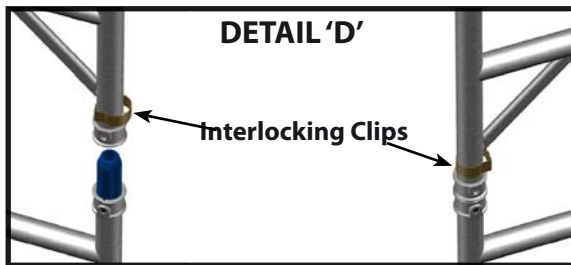

10. Attach one BetaGuard® frame set as near to frame vertical as possible between tower frames at 1st and 4th rungs of upper frames at a suitable distance apart to allow for the placing of a trapdoor platform.

11. Attach another BetaGuard® frame to the centre of the tower to the ladder edge (opposite existing BetaGuard® frame) to provide protection to ladder.

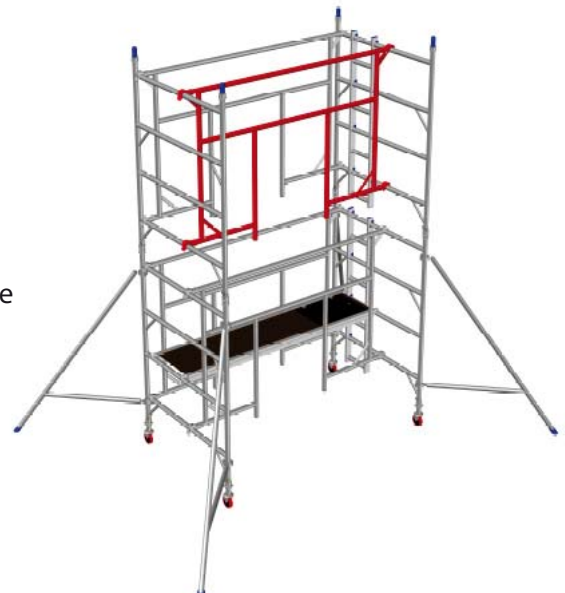

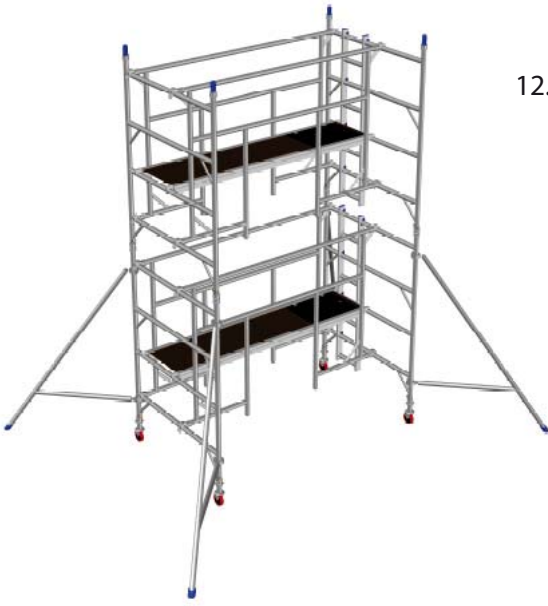

12. Place trapdoor platform at 3m platform height between BetaGuard® frames (above platform placed at lower level) ensuring that platform trap is placed to the ladder side of the tower.

Repeat steps 9 to 12 until desired height has been reached (max. height 8m outdoors and 12 m indoors) until top platform is to be installed.

ASSEMBLING UPPER FRAMES

TOP (WORKING) PLATFORM SECTIONS

Every Working platform, whether it is situated at the top or between intermediate sections (ODD or EVEN height tower) is assembled using the same components and steps that follow.



13. Add one ladder frame and one span frame on top of existing ladder and span frames, respectively.

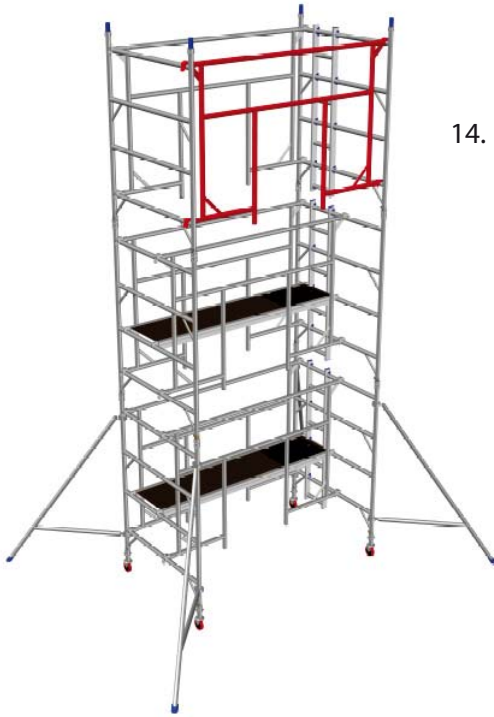

14. Attach two BetaGuard® frames between upper tower frames on 1st and 4th rungs set as near to frame verticals as possible on opposite sides of the tower.

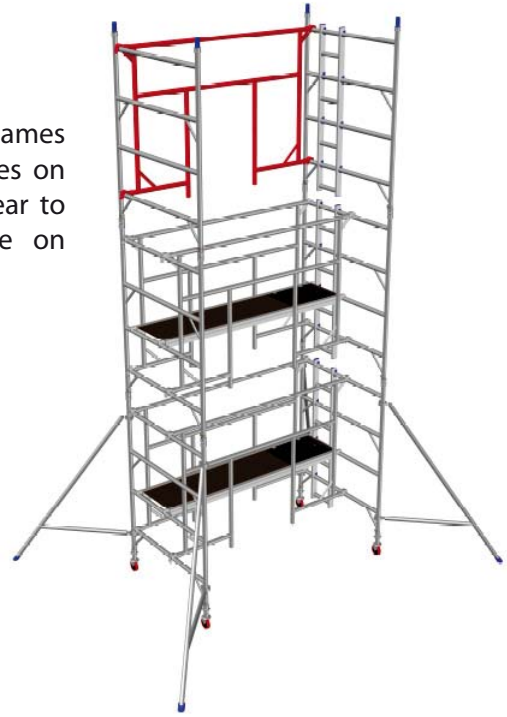

15. Place fixed platform to opposite side of tower, from where operative is standing below,



16. Place trapdoor platform ensuring that trap is placed at same side to trap on platform below.
Note Ensure that the trapdoor hinge is to the outside edge.

17. Fit toeboards to all working platforms.

Scaffold is complete.

DISMANTLING THE TOWER

The dismantling procedure is simply a reversal of the steps explained for the assembly.

For your safety and that of others, take particular care not to allow components to fall to the ground since this will not only result in damage but may cause serious injury.

ODD HEIGHT TOWERS

THE BASE SECTION (1.7m; 3.7m; 5.7m; 7.7m; 9.7m; 11.7m)

The following instructions are for Odd height towers with additional platform heights of 0.5m as detailed above (see *Quantities Schedule - pages 33 & 34 for equipment to suit*).

1. Fit four legs to four castors (or base plates) and then turn the height adjustment collar on each leg until approximately 100mm from the lower end.
2. Set each castor brake on by moving the brake lever fully down.

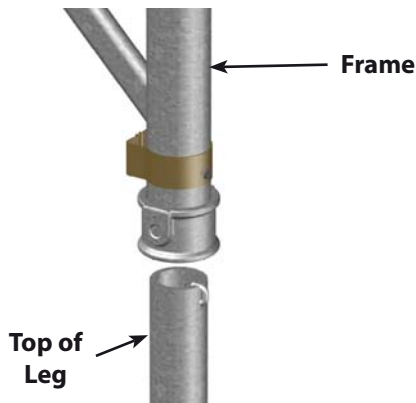
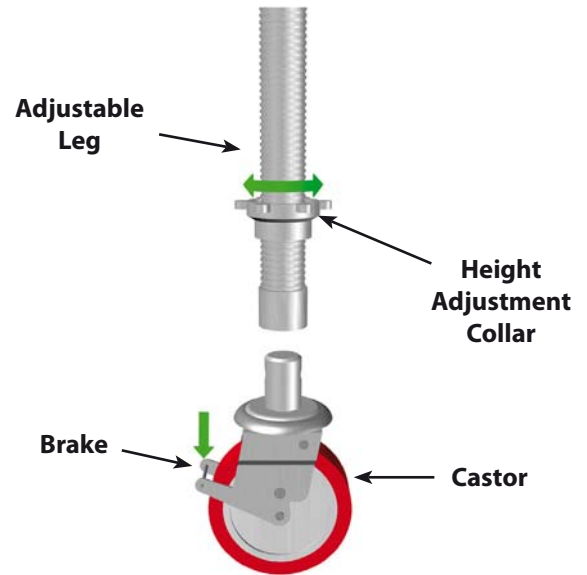

3. Fit leg assemblies to one 4 rung span frame and one 4 rung ladder frame. Insert each leg until the collar is in contact with the frame's tubing.

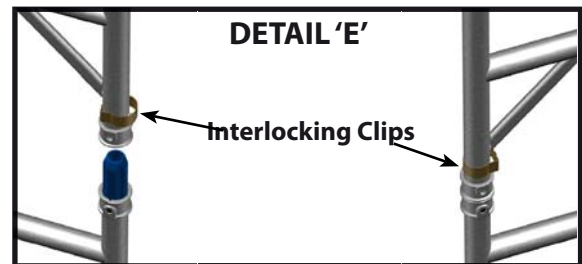

4. Add a 2 rung ladder frame to a 3 rung ladder frame (using 2 operatives) and lock frames together.

Note Ensure that the interlocking clips provided are correctly fitted and engaged (Detail 'E') when locking these and all subsequent frames.

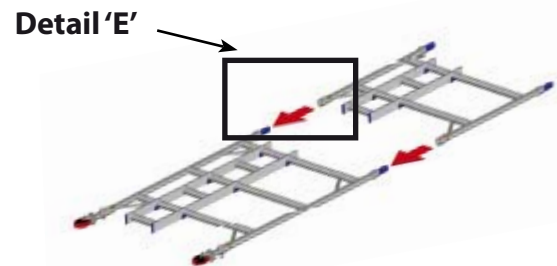

5. Raise combined frames (ensuring that castors are locked) and attach the BetaGuard® frame at 1st and 4th rungs of tower frame set as near as possible to frame vertical.

Note It is strongly recommended that 2 operatives carry out this step



6. Attach BetaGuard® frame to the opposing combined tower span frames and square the two frames to each other.

Note *It may be advantageous to place a platform at low level to assist in "squaring" tower.*

7. With the aid of a spirit level, you should now make any necessary adjustments to level the tower by turning the adjustment collars.

Note *Remove platform when tower is "square". NEVER stand on an UNGUARDED platform.*

8. Add a BetaGuard® frame to the centre of the tower (approx.) but set one rung above previous BetaGuard® frame at a suitable distance apart to allow for the placing of a trapdoor platform.



9. Add another BetaGuard® frame at the same level as previous BetaGuard® frame (step 8), set as near to frame vertical as possible between tower frames.

Stabilisers

Stabilisers or outriggers shall always be fitted when specified. See Quantity Schedule for the correct stabilisers or outriggers.

Note SP10 stabilisers are extended by 559mm (see below)

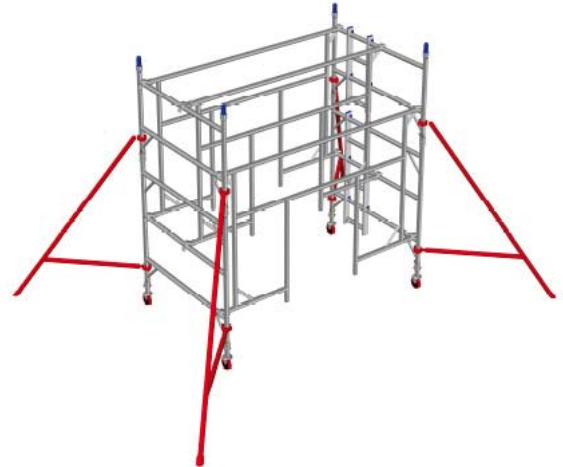

When using standard stabilisers, fit them now.

To attach the stabiliser, fit the upper screw clamp to the frame vertical at a position below the bottom rung of the upper frame, then fit the lower screw clamp as low as possible to the frame upright.

Stabilisers should be attached so that the footprint of the tower, including stabilisers, is a square of the dimensions shown on page 6. Ensure that the stabilisers are in firm contact with the ground.

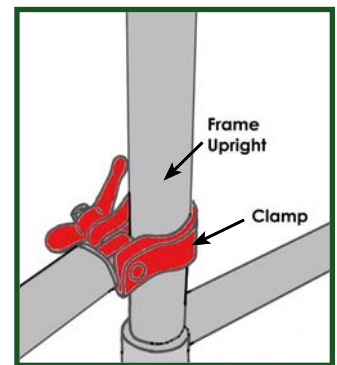

Notes

It may be advantageous to ensure that stabilisers are fitted from frame side as shown.

It may only be possible to fit extended stabilisers after upper frame has been placed.

If repositioning stabilisers when in position then screw clamps MUST be loosened prior to movement then re-fixed.



10. Place trapdoor platform at 1.5m platform height (3 rungs from ground) between BetaGuard® frames ensuring that platform trap is placed to the ladder side of the tower..

ASSEMBLING UPPER FRAMES

INTERMEDIATE SECTIONS

When the base section is complete then assembly of the upper frames can commence.

Every 2m section (intermediate section) between the base section and working platform (whether ODD or EVEN height tower) is assembled using the same components and steps that follow (steps 11 to 14).

11. Add one 4 rung ladder frame and one 4 rung span frame on top of existing ladder and span frames, respectively and lock frames together.

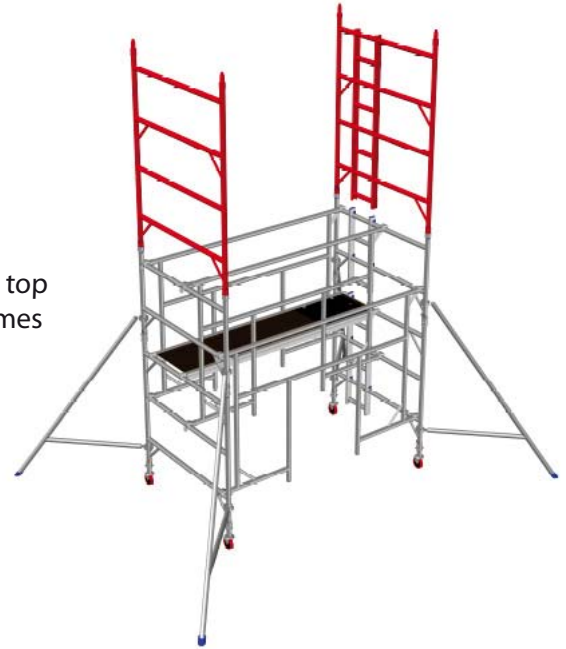
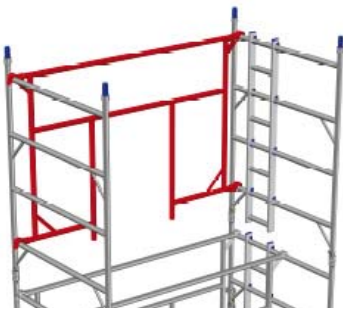

12. Attach one BetaGuard® frame set as near to frame vertical as possible between tower frames at 1st and 4th rungs of upper frames.

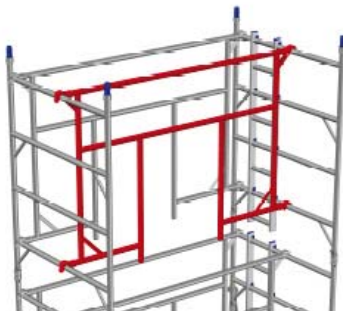

13. Attach another BetaGuard® frame (opposite existing BetaGuard® frame) to the centre of the tower to provide protection to ladder at a suitable distance apart to allow for the placing of a trapdoor platform.

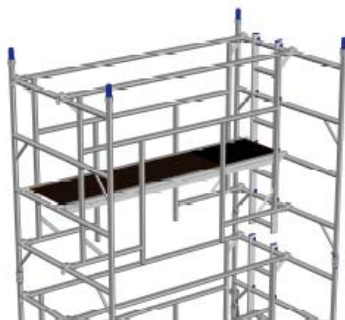

14. Place trapdoor platform at 3.5m platform height between BetaGuard® frames (above platform placed at lower level) ensuring that platform trap is placed to the ladder side of the tower..

Repeat steps 11 to 14 until desired height has been reached (max. height 8m outdoors and 12 m indoors) until top platform is to be installed.

ASSEMBLING UPPER FRAMES

TOP (WORKING) PLATFORM SECTIONS

Every Working platform, whether it is situated at the top or between intermediate sections (ODD or EVEN height tower) is assembled using the same components and steps that follow.

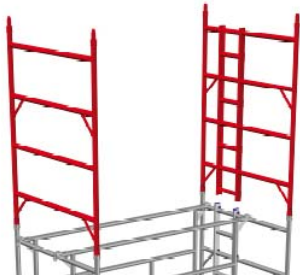

15. Add one 4 rung ladder frame and one 4 rung span frame on top of existing ladder and span frames, respectively and lock frames together.

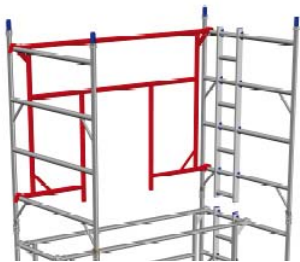

16. Attach two BetaGuard® frames between upper tower frames on 1st and 4th rungs set as near to frame verticals as possible on opposite sides of the tower.

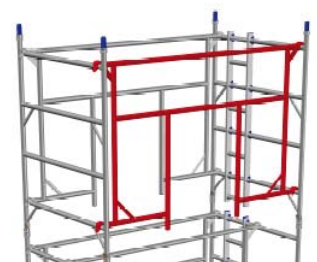

17. Place fixed platform to opposite side of tower, from where operative is standing below,



18. Place trapdoor platform ensuring that trap is placed at same side to trap on platform below.
Note Ensure that the trapdoor hinge is to the outside edge.

19. Fit toeboards to all working platforms.

Scaffold is complete.

DISMANTLING THE TOWER

The dismantling procedure is simply a reversal of the steps explained for the assembly.

For your safety and that of others, take particular care not to allow components to fall to the ground since this will not only result in damage but may cause serious injury.

1450 Mobile Tower - 1.8m and 2.5m (complies with BS EN 1004:2004)

Internal/ External Use

Description	Working Height (m)	3.7	4.7	5.7	6.7	7.7	8.7	9.7	10.7	11.7	12.7	13.7
	Platform Height (m)	1.7	2.7	3.7	4.7	5.7	6.7	7.7	8.7	9.7	10.7	11.7
125/150mm Castor		4	4	4	4	4	4	4	4	4	4	4
250mm Adjustable Leg		4	4	4	4	4	4	4	4	4	4	4
1450 2 Rung Ladder Frame		1		1		1		1		1		1
1450 2 Rung Span Frame		1		1		1		1		1		1
1450 3 Rung Ladder Frame		1	1	1	1	1	1	1	1	1	1	1
1450 3 Rung Span Frame		1	1	1	1	1	1	1	1	1	1	1
1450 4 Rung Ladder Frame			1	1	2	2	3	3	4	4	5	5
1450 4 Rung Span Frame			1	1	2	2	3	3	4	4	5	5
1.8m and 2.5m Fixed Deck		1	1	1	1	1	1	1	1	1	1	1
1.8m and 2.5m Trap Door Deck		1	2	2	2	2	3	3	4	4	5	5
1.8m and 2.5m BetaGuard® Frame		3	4	5	6	7	8	9	10	11	12	13
1.8m and 2.5m Side Toeboard		2	2	2	2	2	2	2	2	2	2	2
0.6m End Toeboard		2	2	2	2	2	2	2	2	2	2	2
SP7 Fixed Stabiliser			4	4	4	4						
SP10 Telescopic Stabiliser (559mm Extension)							4	4	4	4	4	4
Total Tower self weight (kgs) 1.8m		108	157	177	194	214	254	274	306	326	358	378
Total Tower self weight (kgs) 2.5m		120	173	194	211	232	276	297	333	354	391	411

Note 200mm castors were used in the self weight calculations as detailed in the Quantity Schedule above.

Maximum Safe Working Loads (S.W.L.)

300kg per platform evenly distributed.

600kg per tower evenly distributed.

The load **MUST** be evenly distributed over entire platform area.

A maximum of 2 platform levels may be loaded.

The self weight of the tower components is not part of the 600kg S.W.L. per tower and has already been taken into account.

Note You may increase the allowable Safe Working Load to 900kg by ensuring that all even height towers have two BetaGuard® frames in the base. Please contact your supplier if you require further information.

The Quantity Schedule provides for double handrails to all platforms. Toeboards have been included to one working platform only therefore additional toeboards will have to be added to any other levels that are used as working platforms and/ or for storage of materials.

Furthermore, product standards require that towers have platforms placed at least every 4m. The Schedule exceeds this requirement.

The Beta Tower® will be built safely and therefore compliance with the requirements of the Work at Height Regulations 2005 will also be met, if the schedule is followed.

Ballast: Internal/ External Use

Ballast is not required on Beta Tower® if using stabilisers as detailed on Quantity Schedule.

850 Mobile Tower - 1.8m and 2.5m (complies with BS EN 1004:2004)

Internal/ External Use

Description	Working Height (m)	3.7	4.7	5.7	6.7	7.7	8.7	9.7	10.7	11.7	12.7	13.7
	Platform Height (m)	1.7	2.7	3.7	4.7	5.7	6.7	7.7	8.7	9.7	10.7	11.7
125/150mm Castor		4	4	4	4	4	4	4	4	4	4	4
250mm Adjustable Leg		4	4	4	4	4	4	4	4	4	4	4
850 2 Rung Ladder Frame		1		1		1		1		1		1
850 2 Rung Span Frame		1		1		1		1		1		1
850 3 Rung Ladder Frame		1	1	1	1	1	1	1	1	1	1	1
850 3 Rung Span Frame		1	1	1	1	1	1	1	1	1	1	1
850 4 Rung Ladder Frame			1	1	2	2	3	3	4	4	5	5
850 4 Rung Span Frame			1	1	2	2	3	3	4	4	5	5
1.8m and 2.5m Trap Door Deck		1	2	2	2	2	3	3	4	4	5	5
1.8m and 2.5m BetaGuard® Frame		3	4	5	6	7	8	9	10	11	12	13
1.8m and 2.5m Side Toeboard		2	2	2	2	2	2	2	2	2	2	2
0.6m End Toeboard		2	2	2	2	2	2	2	2	2	2	2
SP7 Fixed Stabiliser			4	4	4	4						
SP10 Telescopic Stabiliser (559mm Extension)							4	4	4	4	4	4
Total Tower self weight (kgs) 1.8m		89	136	154	170	188	219	245	275	294	324	343
Total Tower self weight (kgs) 2.5m		96	148	167	183	201	237	263	298	317	352	371

Note 200mm castors were used in the self weight calculations as detailed in the Quantity Schedule above.

Maximum Safe Working Loads (S.W.L.)

300kg per platform evenly distributed.

600kg per tower evenly distributed.

The load **MUST** be evenly distributed over entire platform area.

A maximum of 2 platform levels may be loaded.

The self weight of the tower components is not part of the 600kg S.W.L. per tower and has already been taken into account.

Note You may increase the allowable Safe Working Load to 900kg by ensuring that all even height towers have two BetaGuard® frames in the base. Please contact your supplier if you require further information.

The Quantity Schedule provides for double handrails to all platforms. Toeboards have been included to one working platform only therefore additional toeboards will have to be added to any other levels that are used as working platforms and/ or for storage of materials.

Furthermore, product standards require that towers have platforms placed at least every 4m. The Schedule exceeds this requirement.

The Beta Tower® will be built safely and therefore compliance with the requirements of the Work at Height Regulations 2005 will also be met, if the schedule is followed.

Ballast: Internal/ External Use

Ballast is not required on Beta Tower® if using stabilisers as detailed on Quantity Schedule.

TRAINING

These instructions do not take the place of proper training. Consult your supplier for details of specific training courses for users of mobile access towers.

TOEBOARDS

Whichever position the working platform is assembled, toeboards must be fitted.

Slot the toeboard set together and position on the outer edge of the platform.

The toeboards are designed so that the side boards overhang the platform and the end boards sit on platform hooks (see illustration).

Note If using one piece folding toeboards then select correct toeboard for the desired tower, unfold and fit in place, retained by raised studs on the platform hooks (as above).

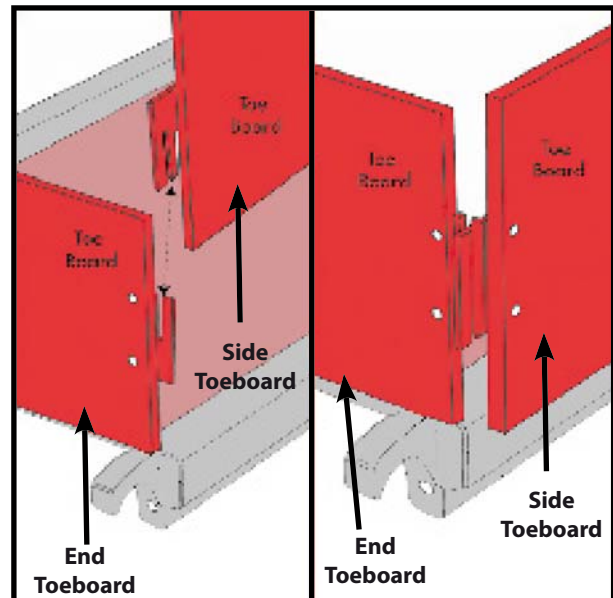

This Erection Guide covers the steps necessary to erect and dismantle a basic tower configuration only.

For other configurations, including full decking at each level (in double width), Wall or Birdcage configuration as well as special design beyond those basic configurations, eg. structures erected from stairways, steep gradients or difficult foundations, use of traditional braces with (or to replace) BetaGuard® - contact the design office.

*Please also note, BetaGuard® may be used as an **"additional" Advanced Guardrail** with traditionally braced tower configuration and other configurations (subject to design).*

Examples of the aforementioned (as complete configurations) are illustrated on the Turner Access website www.turner-access.co.uk

PATENT PENDING GB0813177.3

BetaGuard® is a registered Trademark of Turner Access Ltd

Beta Tower® is a registered Trademark of Turner Access Ltd



For Technical advice (or further information) on Beta Tower®, please contact:
Turner Access Ltd, 65 Craigton Road, Glasgow, G51 3EQ

Tel: +44 (0) 141 309 5555 Fax: +44 (0) 141 309 5436

Beta Tower®